

Assemblage des pièces de n° 1 à 7

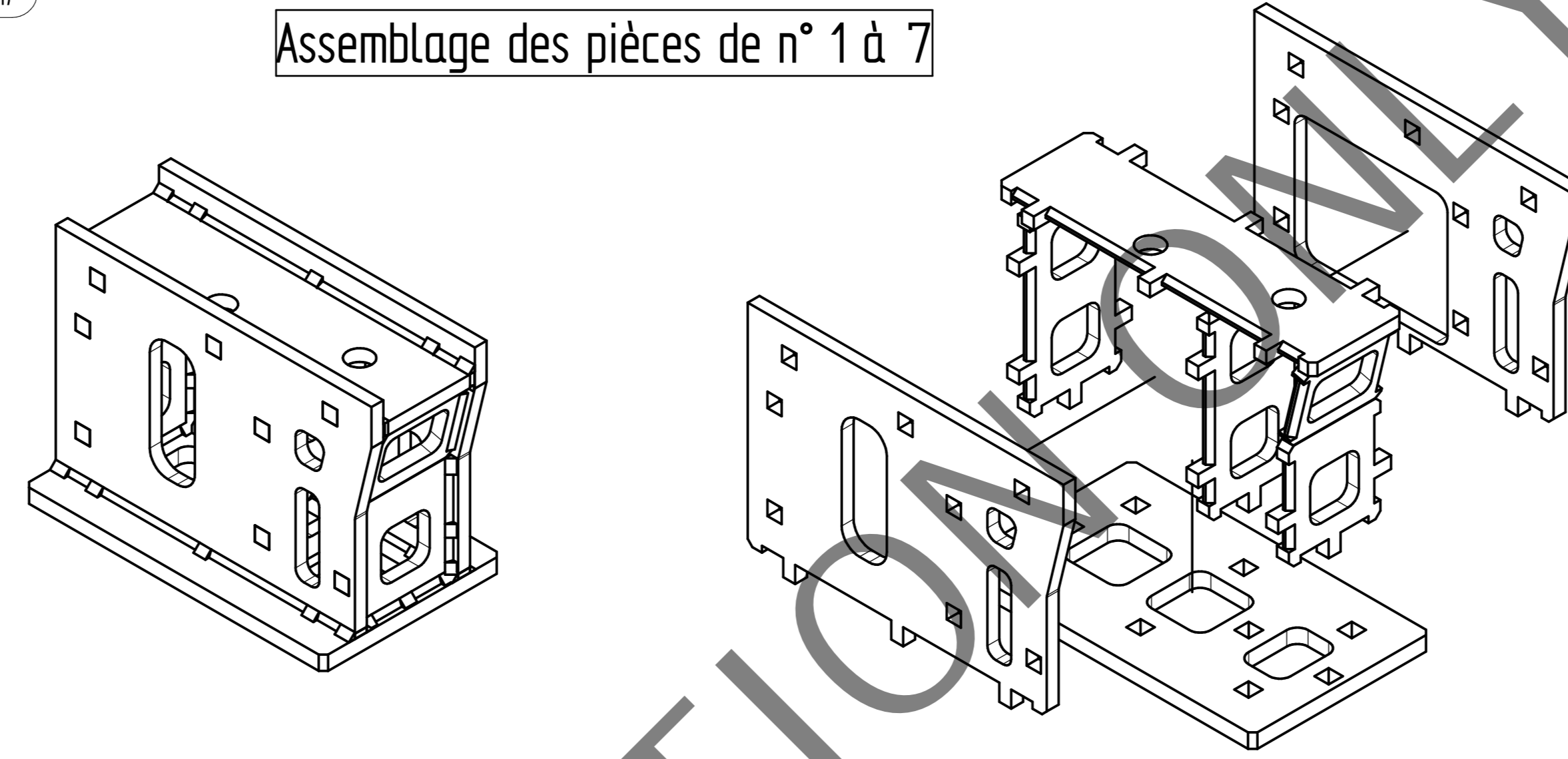

N°	Code Article	Int	Description	Matériaux	Q
1	KD11021		Embase basse	Acier S235JR	1
2	KD11022		Paroi droite	Acier S235JR	1
3	KD11023		Paroi gauche	Acier S235JR	1
4	KD11024		Embase haute	Acier S235JR	1
5	KD11025		Paroi fermeture extérieur	Acier S235JR	1
6	KD11026		Paroi fermeture intérieur	Acier S235JR	2
7	KD11027		Paroi fermeture haute	Acier S235JR	1
8	KD11028		Embase plate 1	Acier S235JR	3
9	KD11029		Embase plate 2	Acier S235JR	1
10	KD11030		Embase plate 3	Acier S235JR	2
11	KD11031		Embase plate 4	Acier S235JR	1

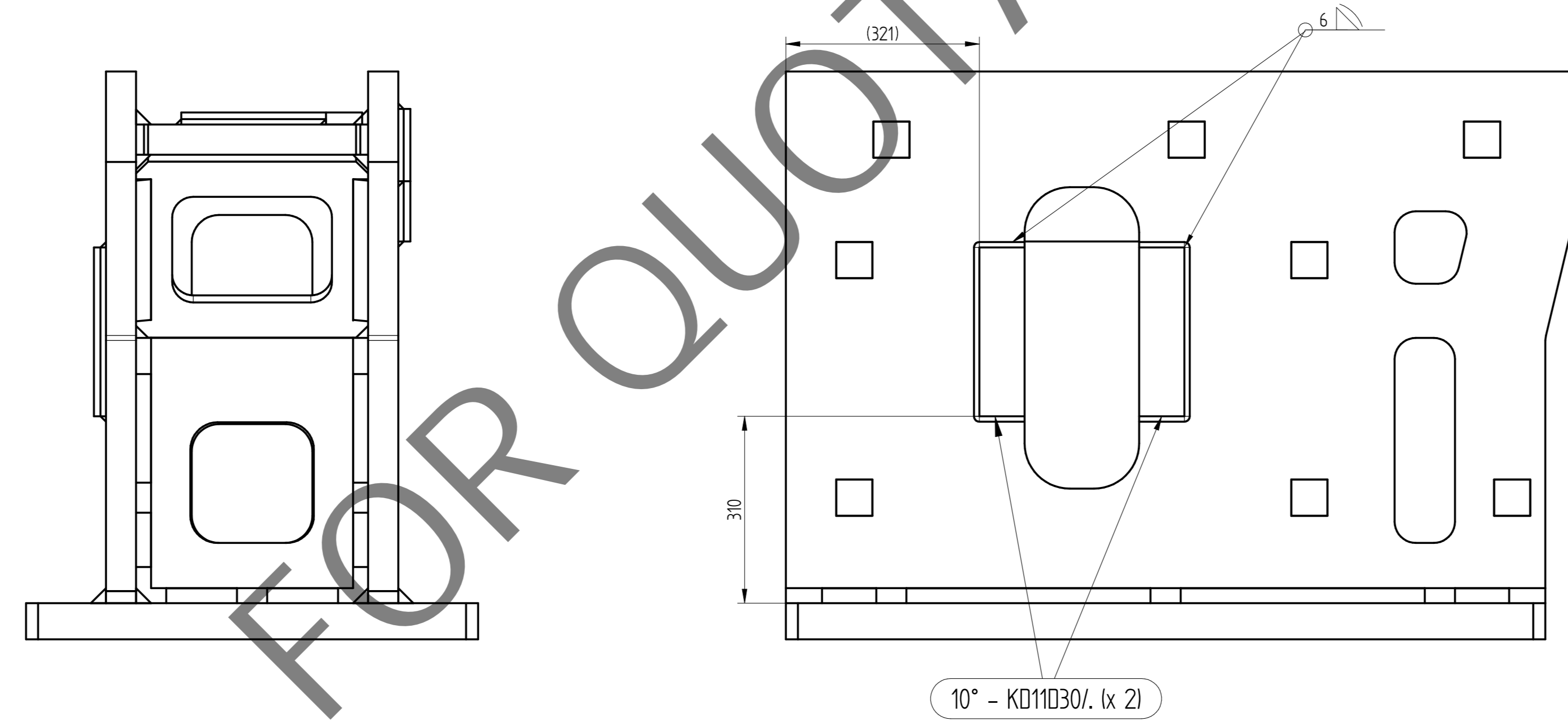
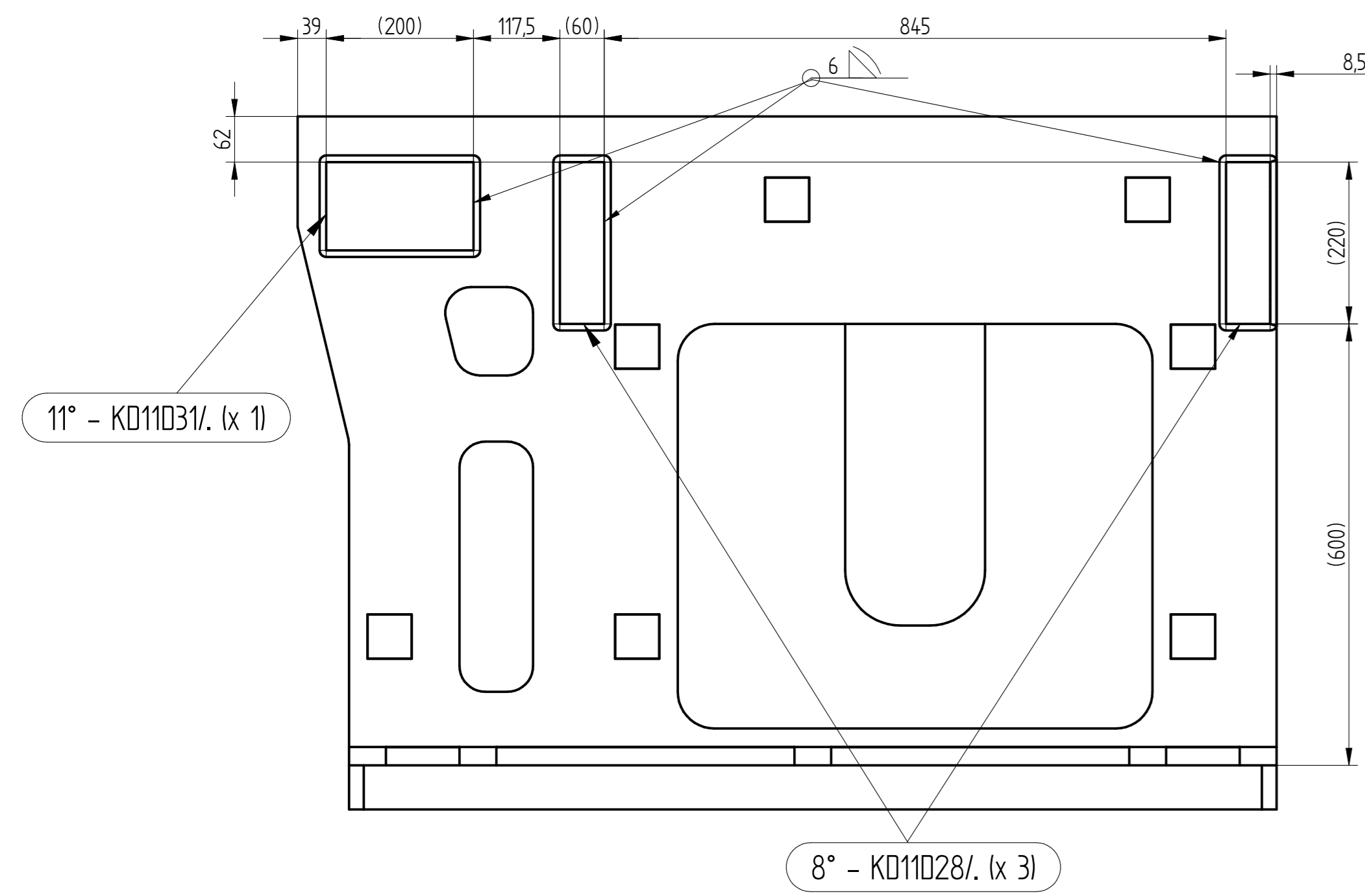
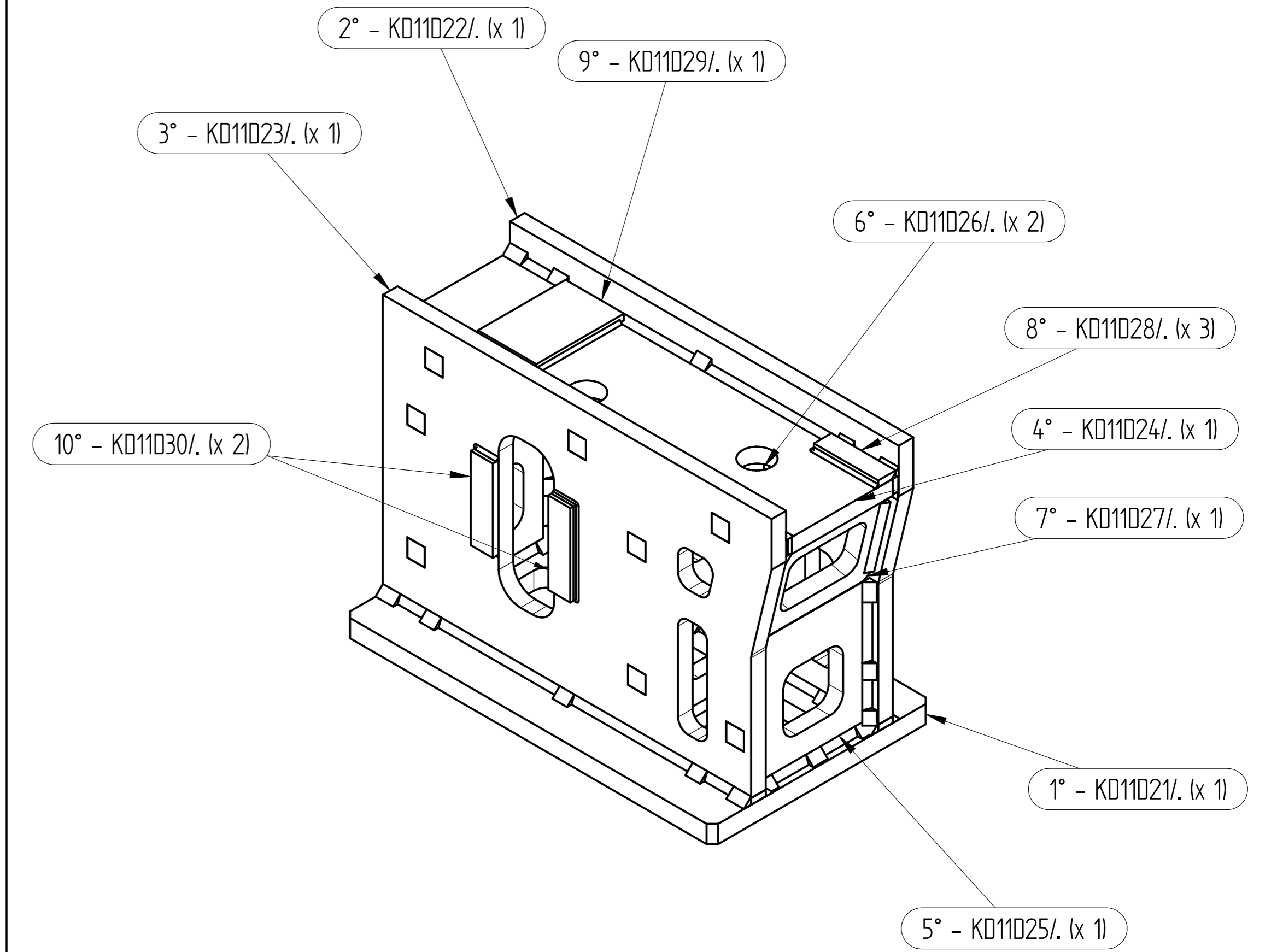

Ajout des embases n° 8, 9, 10 et 11

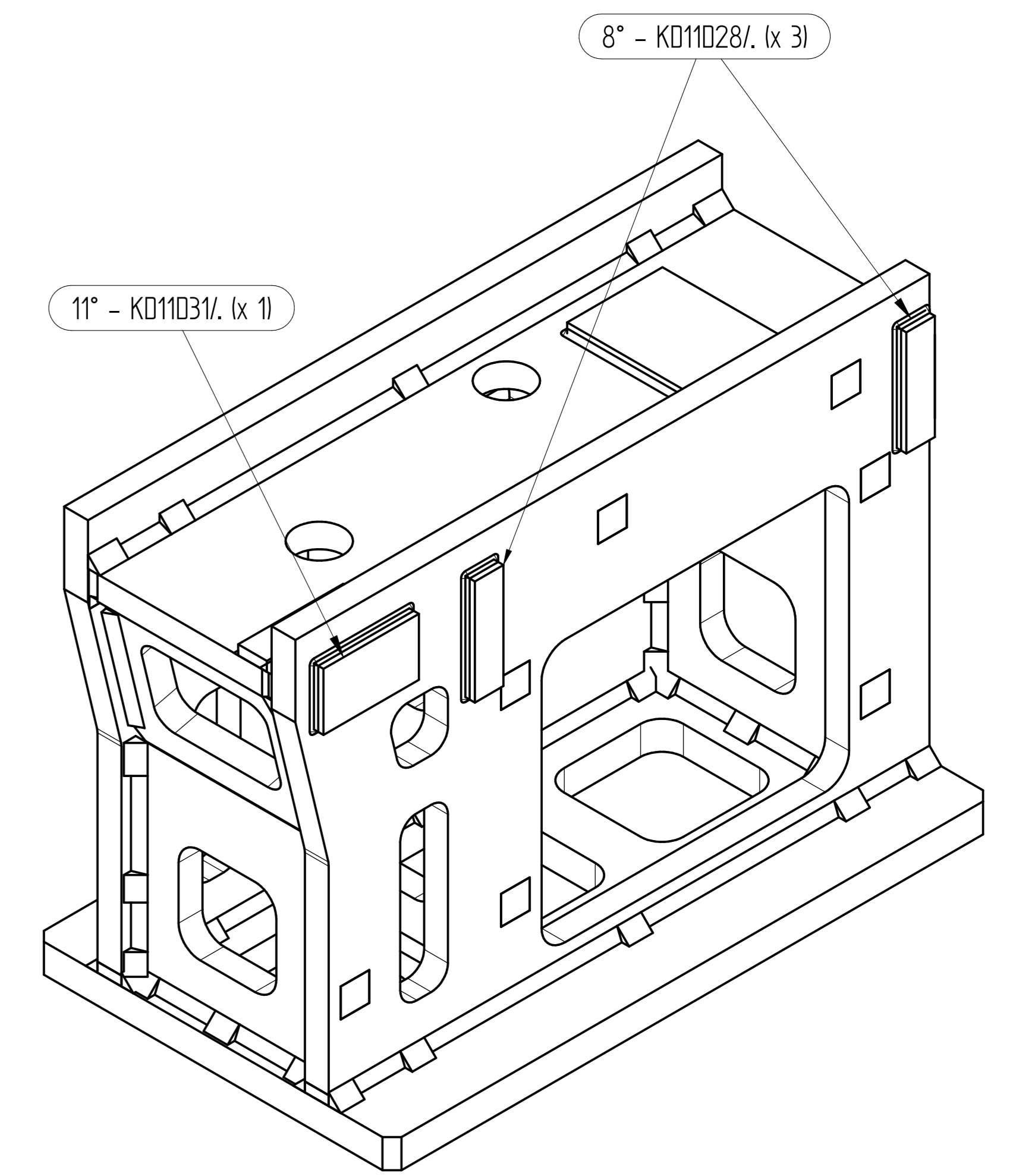
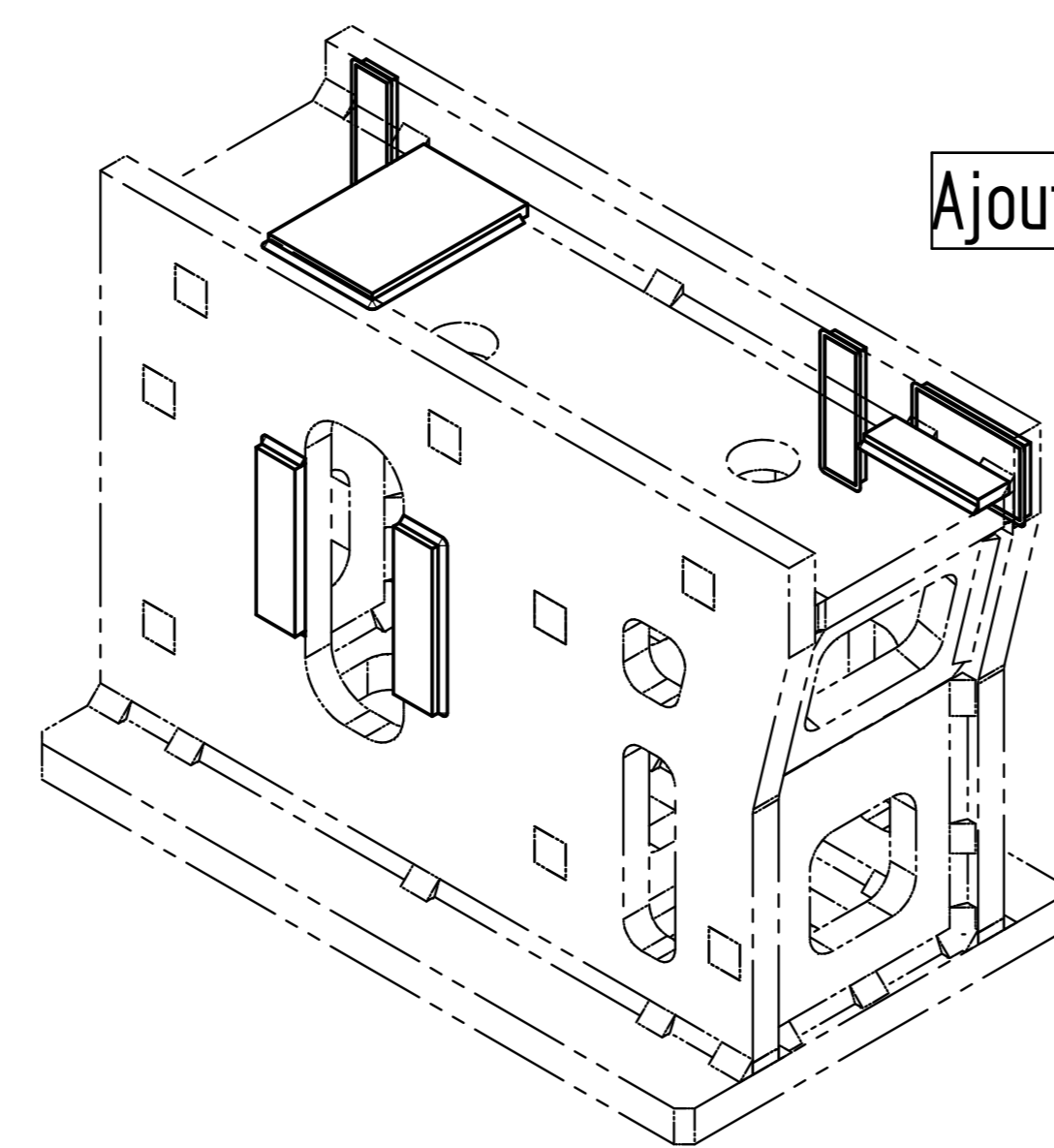

MATIERE / MATERIAL		TRAITEMENT / TREATMENT		PROTECTION	
Voir Dessin					
DRN TITL	050 159230-00	REV 07/15	16-17	DATE	08/06/2023
DESIGNATION	Support boîtier commande mécano-soudé		PROJ. / PROJ.	DR	08/06/2023
Support boîtier commande mécano-soudé			PROJ. / PROJ.	DR	08/06/2023
Driving box support			PROJ. / PROJ.	DR	08/06/2023
KOMPRI CHAMBERON			FILED	1/1	A0